

LUG TYPE BUTTERFLY VALVE Z 014-A

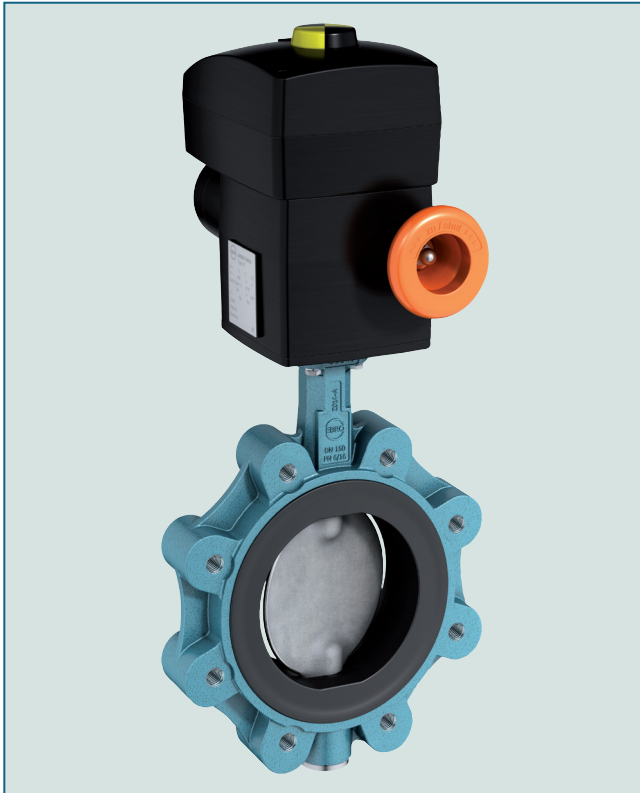

Lug type butterfly valve with threaded holes. This type enables the one-sided lugging of pipes.

TECHNICAL DATA

Nominal diameter:	DN 20 - DN 600 (DN 20 only PN10/16)
Face-to-face:	EN 558 Series 20 ISO 5752 Series 20 API 609 Table 1
Flange accommodation:	EN 1092 PN 6/10/16 ASME Class 150 AS 4087 PN 16
Flange Surface Design:	EN 1092 Form A/B ASME RF, FF
Top flange:	EN ISO 5211
Marking:	EN 19
Tightness check:	EN 12266 (Leakage rate A) ISO 5208, Category 3
Temperature range:	-40°C to +200°C (depending on pressure, medium and material)
Operating pressure:	max. 16 bar

FEATURES

- Absolutely tight sealing with flow in either direction
- The valve body and disc are accurately machined which results in low operating torque and long service life and reliability
- Triple shaft bearings prevent shaft deflection and guarantee optimum guidance even after many years of operating service
- Can be disassembled, material-specific recycling possible
- Single flange mounting is possible
- Can be installed in any desired position
- Maintenance-free
- For paint and laquers, a silicone-free version is available

GENERAL APPLICATIONS

- Chemical and petrochemical industries
- Water and waste water technology
- Pneumatic materials handling technology
- Shipbuilding
- Power generation industry
- Food industry
- Civil engineering

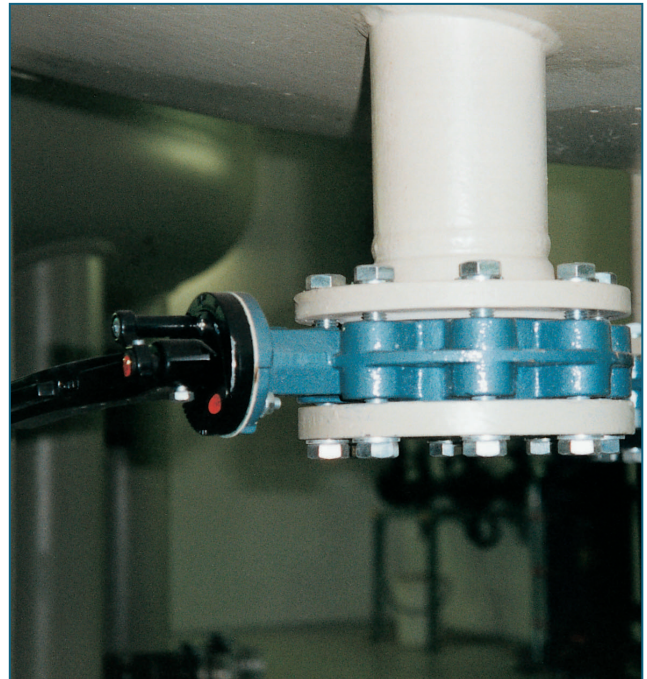

LUG TYPE BUTTERFLY VALVE Z 014-A

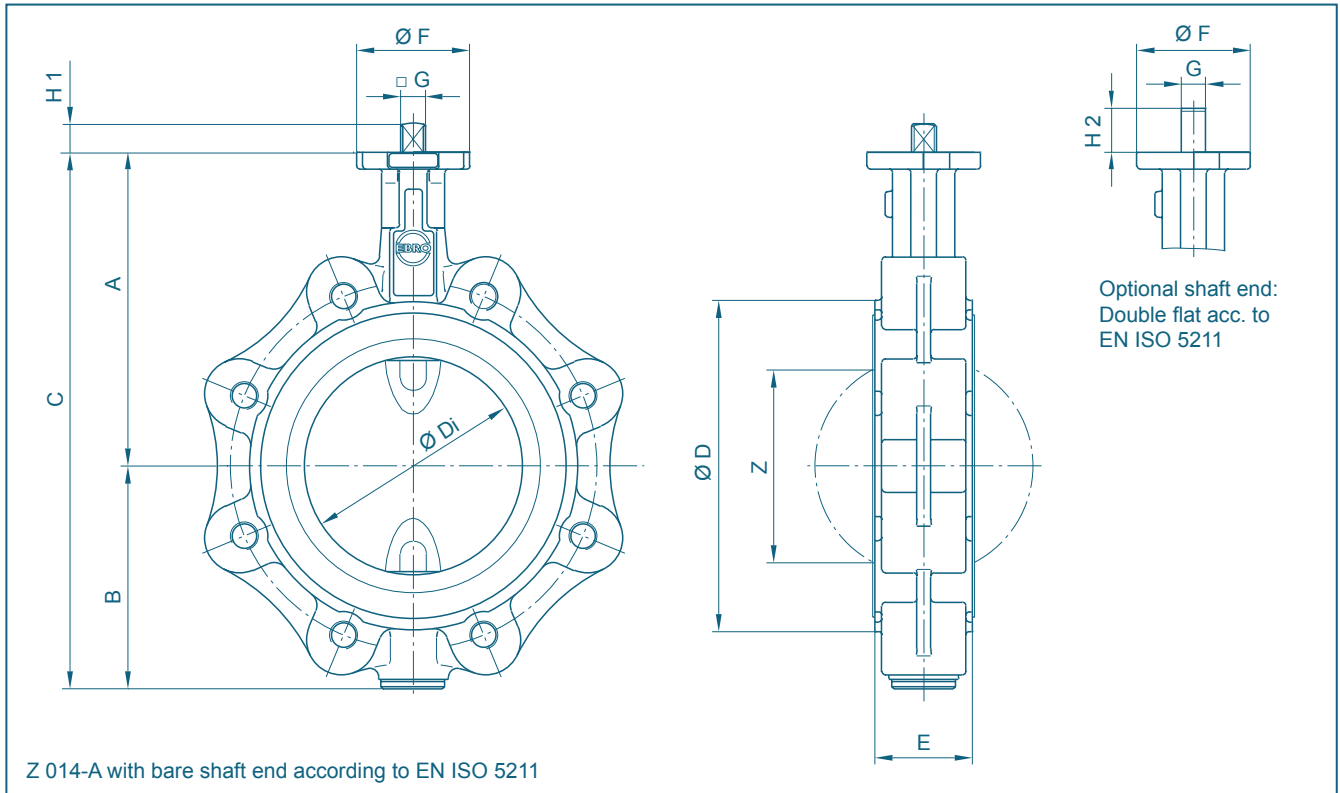

DN [mm]	Size [in]	Dimensions [mm]											Weight[kg] (GG-25)		
		A	B	C	D	Di	E	F	Flange	G	H1	H2	Z	Splitted shaft	TS- shaft
20	¾	104	45	149	63	31,5	33	54	F04	11	12	19	-	2,1	-
25	1	104	45	149	63	31,5	33	54	F04	11	12	19	-	2,1	-
32	1¼	104	50	154	68	31,5	33	54	F04	11	12	19	-	2,1	-
40	1½	113	66	179	80	38	33	54	F04	11	12	19	22	4,0	-
50	2	126	84	210	95	48,5	43	54	F04	11	12	19	25	4,8	-
65	2½	134	93	227	115	63,5	46	54	F04	11	12	19	45	5,5	-
80	3	157	104	261	138	78,5	46	65	F05	14	16	25	65	8,6	9,1
100	4	167	115	282	158	98,5	52	65	F05	14	16	25	85	9,8	10,4
125	5	180	127	307	188	123,5	56	65	F05	14	16	25	111	10,1	10,7
150	6	203	150	353	210	148	56	90	F07	17	19	30	139	13,1	14,6
200	8	228	176	404	268	199	60	90	F07	17	19	30	190	18,8	20,6
250	10	266	212	478	320	248	68	125	F10	22	24	39	240	29,5	32,5
300	12	291	237	528	370	296	78	125	F10	22	24	39	287	37,0	40,5
350	14	332	269	601	408	338	78	150	F12	*	*	-	330	54,8	60,4
400	16	363	314	677	470	388	102	150	F12	*	*	-	378	81,5	87,3
450	18	397	335	732	530	430,5	114	210	F16	*	*	-	417	101,4	105,9
500	20	437	371	808	574	494,5	127	210	F14/F16	*	*	-	474	136,3	142,8
600	24	498	469	967	675	590	154	300	F16/F25	*	*	-	563	240,5	267,5

* According to mounted actuator

Subject to change without notice

LUG TYPE BUTTERFLY VALVE Z 014-A

MATERIAL SPECIFICATION AND PARTS LIST

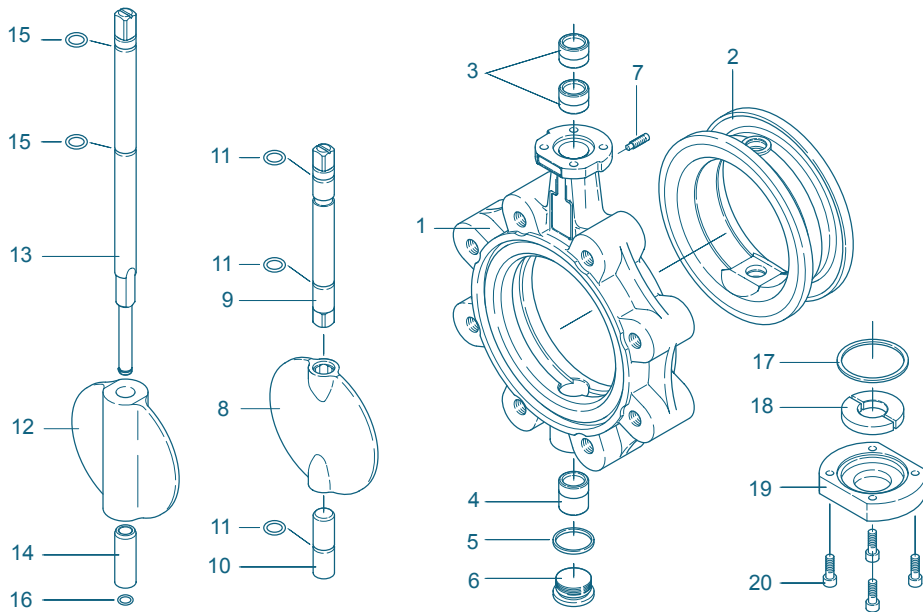

TS-Version

Version with splitted shaft

Pts. 17-20:
Cover plate for
valve \geq DN 350

Pt.	Description	Material	Material-No.	ASTM	Pt.	Description	Material	Material-No.	ASTM				
1	Body	Nodular Cast Iron	GGG-40	0.7040	9/10	Shafts	Stainless Steel	X14CrMoS17	1.4104	430 F			
			GGG-40.3	0.7043				X5CrNiMo17-12-2	1.4401	316			
2	Seat	NBR					Hastelloy	2.4883	Hastelloy				
		EPDM			11	O-ring	NBR		Nitrile butadiene rubber				
		CSM					FPM		Fluorocarbon rubber				
		FPM			12	TS-disc	Nodular Cast Iron	GGG-40	0.7040	60-40-18			
		VSI					Stainless Steel	G-X5CrNiMo19-11-2	1.4408	CF8M			
		SBR-green					Aluminium Bronze	G-CuAl10Ni	2.0975	C 95800			
3/4	Bearing bush	Brass	MS 58	2.0401			Coating	Halar, Rilsan					
		Polyamide	PA 66				Surface quality	electropolished, mirror finished					
		PTFE	Polytetrafluorethylene			13	TS-shaft	Stainless Steel	X14CrMoS17	1.4104	430 F		
5	Seal DIN 7603	Copper					X39CrMo17-1	1.4122					
							X5CrNiMo17-12-2	1.4401	316				
6	Plug screw DIN 908	Stainless Steel	G-X5CrNiMo19-11-2	1.4408	14	Sleeve	Stainless Steel	X5CrNi18-10	1.4301	304			
7	Plug screw DIN 915	Steel	45 H galvanized		15	O-ring	NBR		Nitrile butadiene rubber				
		Stainless Steel	A4-70					FPM		Fluorocarbon rubber			
8	Disc	Steel	ST 52.3	1.0570	16	Retaining ring	Stainless Steel	X39CrMo17-1	1.4122				
		Stainless Steel	X5CrNi18-10	1.4301	304	17	O-ring	NBR		Nitrile butadiene rubber			
			G-X5CrNiMo19-11-2	1.4408	CF8M				Acrylonitrile butadiene rubber				
			X2CrNiMo17-12-2	1.4404	316 L			18	Shaft retainer	Brass	MS 58	2.0401	B 45
			X6CrNiMoTi17-12-2	1.4571	316 Ti			19	Cover plate	Grey Cast Iron	GG-25	0.6025	40 B
			G-X2CrNiMoN26-7-4	1.4469	F 51					20	Screw	Steel	45 H galvanized
	Hastelloy	2.4883	Hastelloy		Stainless Steel			A2-70				B 8	
	Aluminium Bronze	G-CuAl10Ni	2.0975	C 95800			A4-70		B8M				
	Coating	Halar, Rilsan, NBR, EPDM											
	Surface quality	electropolished, mirror finished											
	Other materials upon request												

Subject to change without notice

LUG TYPE BUTTERFLY VALVE Z 014-A

TORQUE

- The values listed in the table are initial breakaway torques, taken with liquids and lubricant media.

- Please regard these as approximate values, as the objective value depends on different factors like pressure, medium, rubber, quality, temperature ... etc.

- Our engineers look forward to help you with exact values for your application.

- Powdery (non-lubricant) media
Md x 1,3

- Dry gases/high viscous media
Md x 1,2

DN [mm]	Size [in]	Adapted Disc Size Pressure Rating			
		3 bar disc	6 bar disc	10 bar disc	16 bar disc
20	¾	5	5	5	-
25	1	5	5	5	-
32	1¼	5	5	5	-
40	1½	8	8	8	8
50	2	9	9	9	9
65	2½	18	18	18	18
80	3	8	10	18	24
100	4	9	18	28	37
125	5	15	22	45	59
150	6	36	45	78	125
200	8	59	76	140	200
250	10	150	180	200	240
300	12	200	240	280	360
350	14	350	540	610	700
400	16	420	620	750	850
450	18	720	746	860	1500
500	20	900	1100	2255	3690
600	24	1050	2100	3000	5830

All values in Nm

K_V-VALUES

- The K_V-values [m³ per hour] is the flow of water at a temperature of 5°C to 30°C (41°F to 86°F) at Δp of 1 bar

- The K_V-values specified are based on tests carried out by the Delfter Hydraulics Laboratories, the Netherlands

- Permissible velocity of flow
V_{max} 4,5 m/s for liquids,
V_{max} 70 m/s for gases

- The throttle function is linear at an angle 30° to 70°

- Avoid cavitation

For further values, please contact our engineers.

DN [mm]	Size [in]	Opening angle α°							
		20°	30°	40°	50°	60°	70°	80°	90°
20	¾	-	1	4	8	11	19	27	32
25	1	-	1,5	5	10	15	24	32	36
32	1¼	-	1,5	5	11	16	27	35	40
40	1½	-	2,2	8	15	21	33	43	50
50	2	1,2	8	13	22	38	50	65	85
65	2½	2	9	22	42	77	115	170	215
80	3	8	24	50	95	150	240	330	420
100	4	13	28	65	130	180	340	550	800
125	5	26	65	130	230	350	530	870	1010
150	6	35	90	200	360	640	900	1350	2100
200	8	43	180	350	580	1000	1600	3000	4000
250	10	125	360	660	1100	1800	3100	5300	6400
300	12	200	550	1000	1600	2600	5000	7500	8500
350	14	350	780	1400	2400	4000	8000	10800	11500
400	16	490	1050	1800	3100	5500	11000	12000	14500
450	18	510	1080	2040	3350	6100	11500	14600	20500
500	20	520	1100	2200	3500	6200	12000	15100	21000
600	24	750	1400	2800	5100	8800	14000	22000	29300

Subject to change without notice