

HIGH PERFORMANCE BUTTERFLY VALVE HP 112

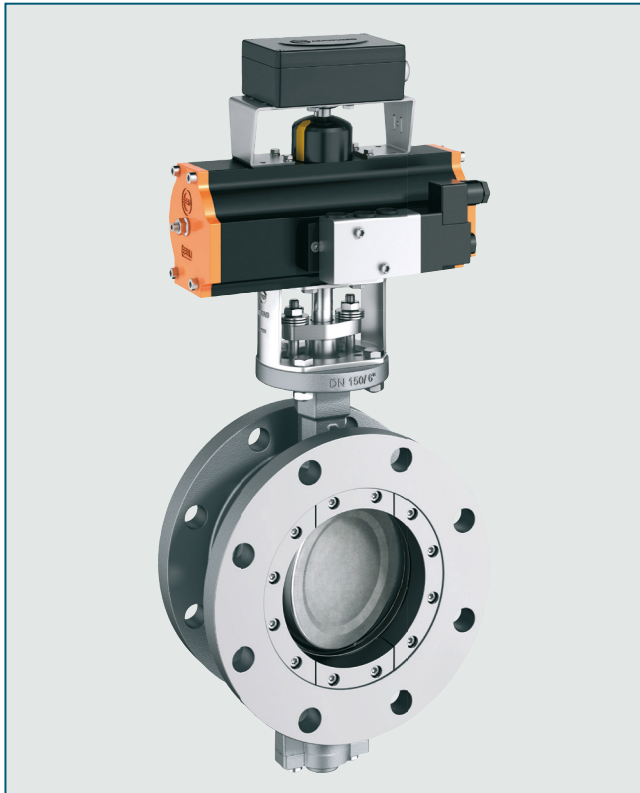

Double-flanged butterfly valve in double-eccentric construction. Reliable sealing even with extreme temperature and pressure conditions.

TECHNICAL DATA

Nominal diameter:	DN 80 - DN 600
Face-to-face::	EN 558 Series 13 others upon request
Flange accomodation:	EN 1092 PN 10/16/25/40 ASME Class 150 ASME Class 300 AS 4087 PN 16/21
Flange Surface Design:	EN 1092 Form A/B ASME RF, FF
Marking:	EN 19
Tightness check	
- for R-PTFE seat:	EN 12266 (Leakage rate A)
- for Inconel seat:	EN 12266 (Leakage rate B) ISO 5208, Category 3
Temperature range:	-60°C bis +600°C
Operating pressure:	≤ DN 150, 40 bar > DN 150, 25 bar
Vacuum:	up to 1mbar absolute

FEATURES

- Shut-off and control valve for gaseous and liquid media
- Disc has double-eccentric bearing
- Seat ring systems available: R-PTFE, Inconel and Fire Safe
- Maintenance-free
- Long service life, even at high switching frequencies
- Seal variants:
 - soft-sealing (R-PTFE) max. 230°C
 - metallic sealing (Inconel) max. 600°C
 - fire safe (PTFE / Inconel) max. 200°C
- Fire safe BS 6755 Part 2, API 607 5th Edition

GENERAL APPLICATIONS:

- Chemical and petrochemical industry
- Hot water and steam systems
- District heat supply
- Vacuum systems
- Shipbuilding
- Gas process technology
- Heavy duty services

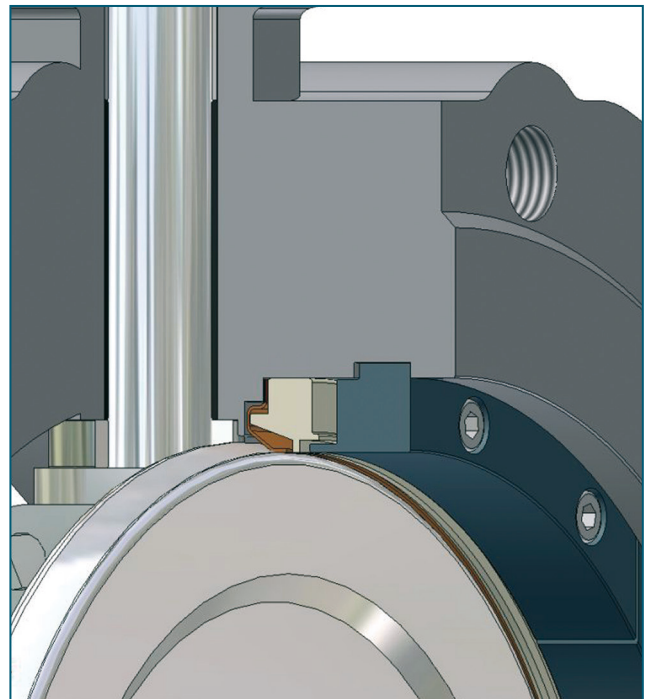

Sealing system with inside metallic thrust collar.

HIGH PERFORMANCE BUTTERFLY VALVE HP 112

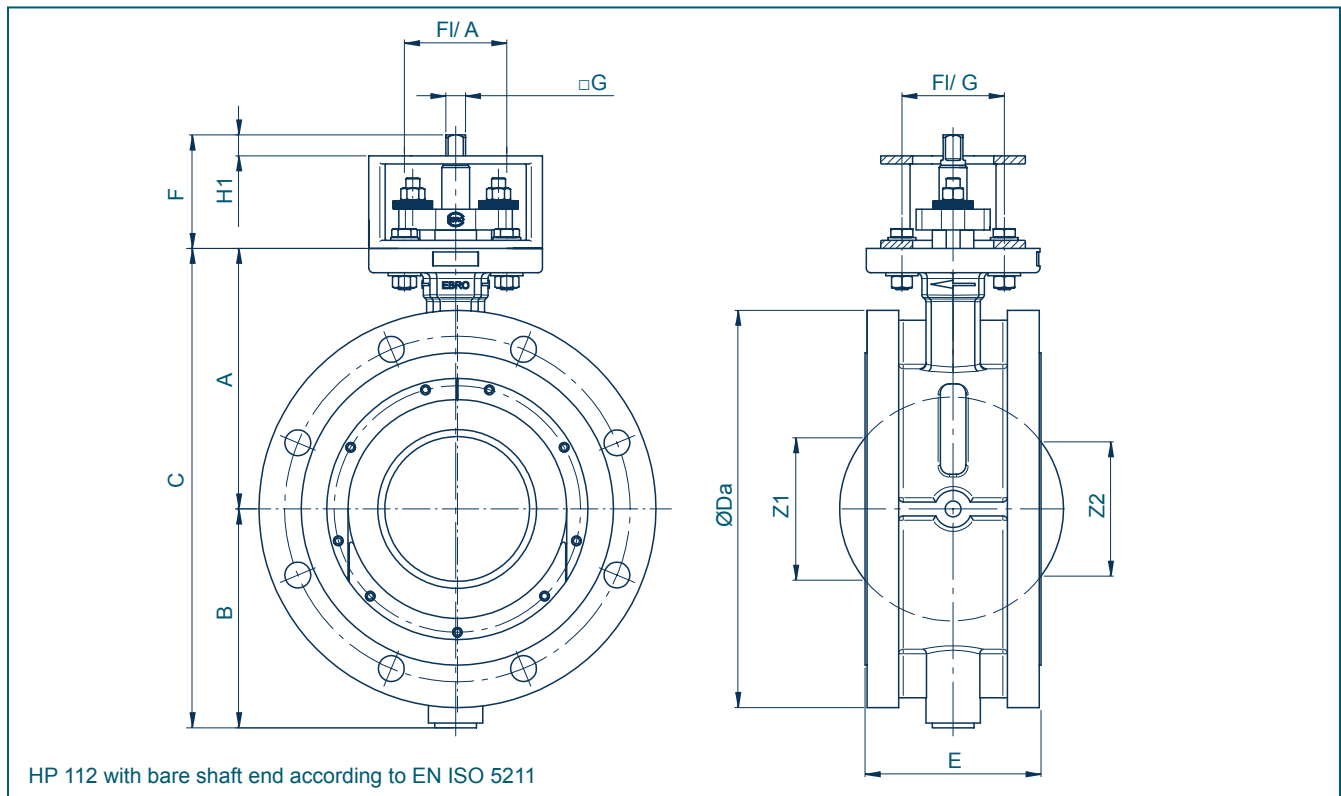

HP 112 with bare shaft end according to EN ISO 5211

DN [mm]	Size [in]	Dimensions [mm]												Weight [kg]			
		A	B	C	ØDa	ØDa	E	F	FL/A	FL/G	G	H1	Z1	Z2	CL 150	CL 300	
				CL 150*	CL 300**												
80	3	142	109	251	191	210	114	95	F05	F07	12	15	-	-	15	19	
100	4	158	122	280	229	254	127	95	F05	F07	12	15	-	-	20	24	
150	6	195	152	347	280	318	140	98	F07	F10	14	18	62	47	32	50	
200	8	225	190	415	343	381	152	98	F10	F12	17	18	123	116	50	70	
250	10	268	220	488	407	444	165	103	F12	F12	22	23	180	174	70	90	
300	12	300	255	555	483	521	178	118	F12	F14	27	28	230	226	105	150	
350	14	345	304	649	534	585	190	128	F14	F14	27	28	276	270	155	210	
400	16	375	340	715	597	648	216	136	F14	F16	36	36	317	311	205	255	
450	18	412	366	778	635	711	222	156	F16	F16	36	36	384	380	245	315	
500	20	441	399	840	699	775	229	166	F16	F16	46	46	428	423	295	385	
600	24	524	468	992	813	914	267	255	F25	F25	55	55	501	494	470	615	

* Acc. to ASME Class 150 max. 19,2 bar

**Acc. to ASME Class 300 DN 200 - DN 600 max. 25 bar

Acc. to ASME Class 300 DN 80 - DN150 max. 40 bar

Subject to change without notice

HIGH PERFORMANCE BUTTERFLY VALVE HP 112

MATERIAL SPECIFICATION AND PARTS LIST

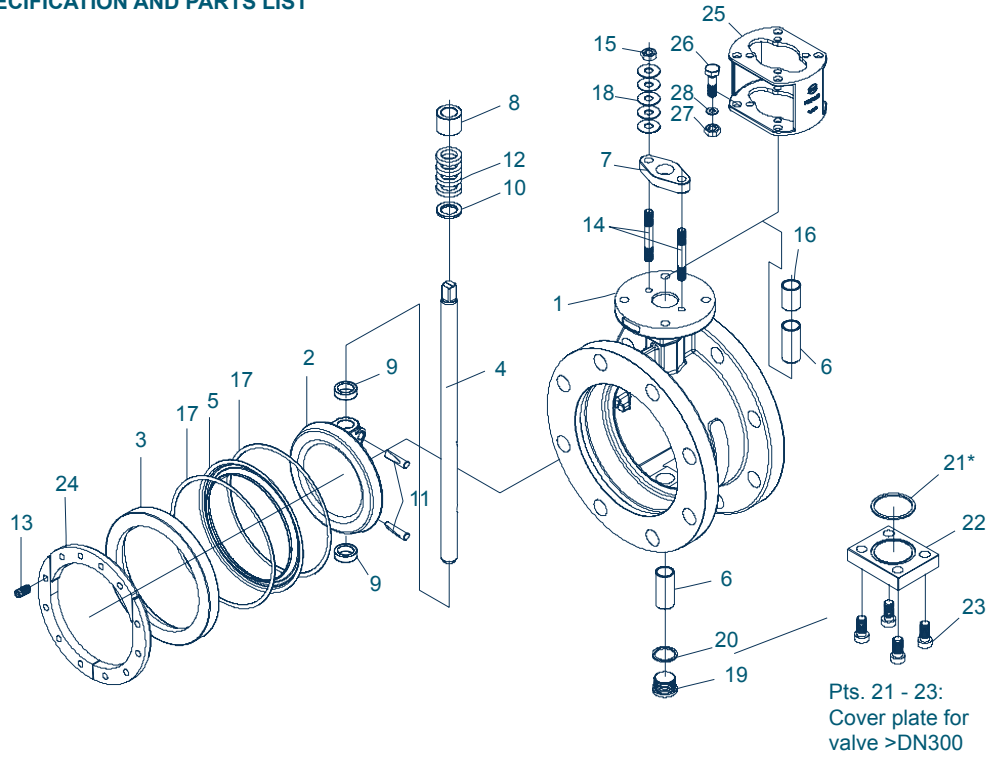

Pos.	Description	Material	Material No.	ASTM	Pos.	Description	Material	Material No.	ASTM				
1	Body	Carbon Steel	GP240GH	1.0619	14	Threaded pin	Stainless steel	A4-70	B 8 M				
		Stainless Steel	G-X5CrNiMo19-11-2	1.4408			CF8M						
2	Disc	Stainless Steel	G-X5CrNiMo19-11-2	1.4408	15	Hex.-nut	Stainless steel	A4-70	B 8 M				
		Stainless Steel	G-X5CrNiMo19-11-2	1.4408			CF8M						
3	Clamping ring	Steel	S235JR	1.0038	16	Spacer sleeve	Stainless steel	X6CrNiMoTi17-12-2	1.4571	316 Ti			
		Stainless Steel	X2CrNiMo17-12-2	1.4404			316 L						
		Stainless Steel	X6CrNiMoTi17-12-2	1.4571			316 Ti						
4	Shaft	Stainless Steel	X4CrNiMo16-5-1	1.4418	17	Graphite seal (for metal seat)	Graphite						
		Stainless Steel	X4CrNiMo16-5-1	1.4418			316 PTFE						
5	Seat ring	R-PTFE	PTFE-Compound		18	Belleville spr. washer	50CrV4	1.4310					
		Inconel	Inconel 625				19	Plug screw	Stainless steel	A2-50	B 8 M		
		Inconel	Inconel 625						Machining steel	11SNPb30	1.0718 ni-pld.	A29	
6	Shaft bearing	Stainless Steel	X5CrNiMo17-12-2	1.4401/PTFE	316 PTFE	20/21*	Seal	Graphite / Copper*					
		Stainless Steel	X6CrNiMoTi17-12-2	1.4571 ni-pld	316 Ti			22	Cover plate	Stainless steel	X5CrNiMo17-12-2	1.4401	304
		Stainless Steel	X6CrNiMoTi17-12-2	1.4571	316 Ti					Stainless steel	G-X5CrNiMo19-11-2	1.4408	CF8M
7	Gland flange	Stainless steel	G-X5CrNiMo19-11-2	1.4408	CF8M	23	Hex.-socket screw	Stainless steel	A4-70	B 8 M			
		Stainless Steel	X5CrNiMo17-12-2	1.4401	304								
8	Thrust collar	Stainless Steel	X2CrNiMo17-12-2	1.4404	304	24	Bearing ring	Stainless steel	X6CrNiMoTi17-12-2	1.4571	316 Ti		
		Stainless Steel	X6CrNiMoTi17-12-2	1.4571	316 Ti								
		Stainless Steel	X6CrNiMoTi17-12-2	1.4571	316 Ti								
9	Bearing ring	Stainless steel	X6CrNiMoTi17-12-2	1.4571 chr-pld.	316 Ti	25	Bracket	Steel	S235JR+AR	1.0038			
		Stainless steel	X2CrNiMoN22-5-3	1.4462 chr-pld									
10	Support washer	Stainless steel	X6CrNiMoTi17-12-2	1.4571	316 Ti	26	Hex. bolt	Steel	St galvanized				
		Stainless steel	X6CrNiMoTi17-12-2	1.4571	316 Ti			Stainless steel	A2-70	B 8			
11	Taper pin	Stainless steel	X4CrNiMo16-5-1	1.4418	27	Washer	Steel	St galvanized					
		Graphite					Stainless steel	A4	8				
12	Shaft seal	PTFE			28	Hex. nut	Steel	St galvanized					
		Stainless steel	A4-70	B 8 M			Stainless steel	A2-70	8				
13	Hex. socket screw	Stainless steel	A4-70	B 8 M									
		Stainless steel	X1NiCrMoCuN25-20-7	1.4529									
									Other materials upon request.				

Subject to change without notice

HIGH PERFORMANCE BUTTERFLY VALVE HP 112

TORQUE

- The values specified are based on the initial breakaway torque. (disc disengages from seat, torque then drops)

DN [mm]	Size [in]	Operating pressure							
		10 [bar]		16 [bar]		25 [bar]		40 [bar]	
		R-PTFE	Inconel	R-PTFE	Inconel	R-PTFE	Inconel	R-PTFE	Inconel
80	3	28	55	30	65	34	90	38	100
100	4	51	90	61	100	80	120	93	140
150	6	125	170	136	220	168	300	220	360
200	8	205	350	260	430	280	505	-	-
250	10	485	505	550	620	600	860	-	-
300	12	584	740	700	970	855	1280	-	-
350	14	740	815	930	1050	1200	1370	-	-
400	16	1150	1530	1640	2240	2460	2900	-	-
450	18	1150	1700	1750	2500	2700	3500	-	-
500	20	1210	2010	1800	2760	2800	4260	-	-
600	24	4000	4500	4600	5740	6200	8080	-	-

All values in Nm

PRESSURE/TEMPERATURE DIAGRAM

- Pressure control line for 1.0619 body material and metal seat
- Pressure control line for 1.4408 body material and metal seat
- - - Pressure control line for R-PTFE

The diagram illustrates the performance of the standard version of our valve type HP. Valves for higher pressure or deviating temperature are available upon request.

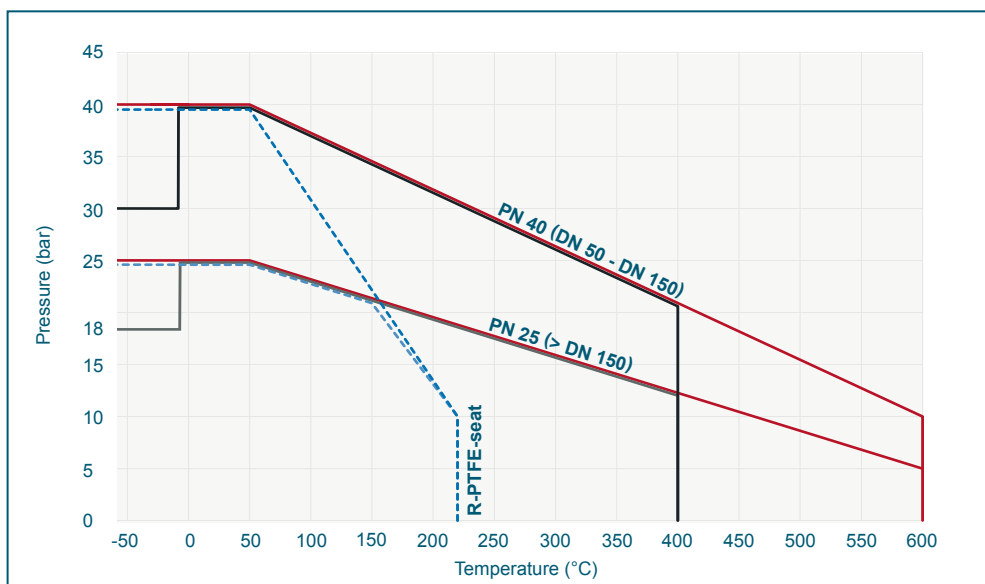

K_V-VALUES

- The K_V-values [m³ per hour] is the flow of water at a temperature of 5°C to 30°C (41°F to 86°F) at Δp of 1 bar

- The K_V-values specified are based on tests carried out by the Delfter Hydraulics Laboratories, the Netherlands

- Permissible velocity of flow
V_{max} 4,5 m/s for liquids,
V_{max} 70 m/s for gases

- The throttle function is linear at an angle 30° to 70°

- Avoid cavitation

For further values, please contact our engineers.

DN [mm]	Size [in]	Opening angle α°							
		20°	30°	40°	50°	60°	70°	80°	90°
80	3	7	30	50	68	82	97	113	115
100	4	22	60	97	119	164	199	223	251
150	6	63	109	162	250	391	588	814	845
200	8	96	168	301	509	742	1107	1581	1747
250	10	264	458	682	980	1421	2083	2882	2889
300	12	397	625	956	1368	1938	2778	3794	3940
350	14	460	720	1100	1650	2500	3400	4800	5400
400	16	550	870	1250	2000	3200	4800	6800	8080
450	18	730	1200	1800	3100	4600	6400	8400	10500
500	20	920	1600	2600	4100	6000	8500	12100	12800
600	24	1370	2250	3780	4950	9000	12500	17100	18500

Subject to change without notice



www.ebro-armaturen.com
post@ebro-armaturen.com

04.2017